

## OUR SECOND-HAND MACHINES

JOUANEL Industrie gives you the opportunity to purchase machines and equipment at rock-bottom prices!

These are second-hand machines taken back from our clients as they bought new JOUANEL equipment, or returning from trade shows and demonstration. They are completely mechanically overhauled, reconditioned up to the current standards, repainted for most of them and ready to operate for many years in your workshops.

You benefit from a 6-month guarantee for these machines.

You can consult our second-hand machines offers on our PDF file, which is regularly updated depending on the current availability...Time to take advantage of our good bargains!

[www.jouanel.com](http://www.jouanel.com)

### **Siège social & Usine • Headquarters & factory**

JOUANEL Industrie • 30 rue des Saulniers  
37800 Sainte-Maure-de-Touraine • FRANCE

Tel.: +33 247 654 067 • Fax: +33 247 655 161

Email : [contact@jouanel.com](mailto:contact@jouanel.com)



## SECOND HAND MACHINES PRICES / 2024

TYPE OF MACHINE	REFERENCES	COMMENTS	GROSS PRICE EXCL. TAX €	N° INTERNES
DECOILLER	DPF153MHM	Revised	13 460,00	OC4090
SLATE CUTTER	CA600E	Revised	900,00	OC5026
MANUAL LEVER-OPERATED SHEAR	CLP1C	Revised	190,00	OC4079
FLARING TOOLS	EVA-GAL80	Revised	150,00	OC5019
ROLLER SHEAR	CCM	Revised	320,00	OC4012
	CCMA	Revised	350,00	OC4013
ACCESSORIES FOR BENDING MACHINE	RCX2040A	Revised	480,00	OC5010
	CCM	Revised		
DOUBLE HINGER BENDERS	PALCD420	Revised	313,00	OC4066
SEAM FOLDER	PLI01K8	Revised	200,00	OC4086
	PLI01NM	Revised	94,00	OC4088
	PLI02NM	Revised	106,00	OC4089
TOOL TO CLOSE HEMS	OFP-180	Revised	160,00	OC4069
HAND EDGE ROLLERS	PLIMSC2-100	Revised	180,00	OC5021
	PLIMSC2-350	Revised	350,00	OC5023
	PLIMDC3-200	Revised	427,00	OC4068
	PLIMDC3-350	Revised	483,00	OC5003 OC5022
	PLIMSD1-040	Revised	182,00	OC5008
PACK BALOUT / TOOLING	BALOUT	Revised	388,00	OC4077
	CBID	Revised		
	CBIG	Revised		
	MACGS	Revised		
	PATHR4K	Revised		
	PATHBL4K	Revised		
	PAR55G	Revised		
	VVDS05	Revised		
	CGRO	Revised		
	CPIDQS	Revised		
	PBTRI100	Revised		
	CBIDS	Revised		
	PBD40	Revised		
	PBC40	Revised		

Would you like more information about this machine?



You can contact +33 2 47 65 47 65 (from Monday to Friday 08h00 / 17h00) or send an email to:

[sav@jouanel.com](mailto:sav@jouanel.com)

Ref. JOUANEL	DPF153MHM
Gross price Excl. Tax	<b>13 460 €</b>
Transport	Not included, possibility to quote the transport
Warranty	6 months, revised
Lead time	

## STANDARD EQUIPMENT

- Non-motorized and manual brake
- Manual hydraulic expansion of 470 to 560 mm



Open Side Decoiller

## GENERAL CHARACTERISTICS

- Width : 1500 mm
- Maximum weight : 3 tons

**Would you like more information about this machine?**



You can contact **+33 2 47 65 47 65** (from Monday to Friday 08h00 / 17h00) or send an email to:  
[sav@jouanel.com](mailto:sav@jouanel.com)

**Vous souhaitez des renseignements complémentaires sur cette machine ?**



Vous pouvez contacter le **02 47 65 47 65** (Du lundi au vendredi 08h00 / 17h00)  
ou envoyer un email à : [sav@jouanel.com](mailto:sav@jouanel.com)

Ref. JOUANEL	CA600E
Gross price Excl. Tax	<b>900 €</b>
Transport	Not included, possibility to quote the transport
Warranty	6 months, revised
Lead time	Available

## STANDARD EQUIPMENT

- Patented aluminum cutting block with ball bearings
- Removable and interchangeable disk
- Square gauges with quick adjustments making easy the positioning of the slate, holding of the cut and mass cut
- 2 gauges with engraved graduations every 5mm
- Universal fastening device for screwdriver, with positioning adjustments and high resistance Velcro holding device
- Shock absorbers when limit of travel
- Large capacity slate chippings tray, easy to remove without any tools, by clamping knobs
- Fixing of the base on a batten and safety fixing by brads
- Large carrying handle - 2 positions



Photo non contractuelle

The CA600E motorized slate cutter allows the cutting of natural or artificial slates in thick thicknesses up to 8 mm. Ideal for series or contract cuts directly on the jobsite.

## GENERAL FEATURES

- Dimensions : 935 x 420 x 250 mm
- Table length : 885 mm
- Table width : 420 mm
- Number of rolling bearings : 8
- Number of square gauges : 5
- Maximum cutting thickness : 8 mm
- Weight : 21,5 kg

Offer available on our website: <https://www.jouanel.com/en/page/second-hand-machines.php>

### Would you like more information about this machine?



You can contact **+33 2 47 65 47 65** (from Monday to Friday 08h00 / 17h00) or send an email to: [sav@jouanel.com](mailto:sav@jouanel.com)

Ref. JOUANEL	CLP1C
Gross price Excl. Tax	<b>190€</b>
Transport	Not included, possibility to quote the transport
Warranty	6 months, revised
Lead time	Available

## STANDARD EQUIPMENT

- Counter spring on the superior blade
- Inferior blade of 150 mm long x 10 mm thick
- Manual blank-holder
- Operating lever



*The pictures shown are not contractual*

Workbench manual lever-operated shears

## GENERAL FEATURES

- Weight : 12 kg
- Dimensions in mm : 280 x 110 x 640
- **Lower blades' height in mm : 125 x 10**

## CAPACITIES

- Cutting galvanized steel on the whole length : 2 mm
- Flat iron in galvanized steel in mm : 60 x 3
- Round iron in galvanized steel in mm : 8
- Movement transmitted by rod

Offer available on our website: <https://www.jouanel.com/en/page/second-hand-machines.php>

**Would you like more information about this machine?**



You can contact **+33 2 47 65 47 65** (from Monday to Friday 08h00 / 17h00) or send an email to:

[sav@jouanel.com](mailto:sav@jouanel.com)



Ref. JOUANEL	EVA-GAL80
Gross price Excl. Tax	150 €
Transport	Not included, possibility to quote the transport
Warranty	6 months
Lead time	Available

## STANDARD EQUIPMENT

- Flaring unit Ø 80
- A perfectly adjusted fit for joining pipes
- Adjustable flaring depth
- Flaring rollers with needle bearings
- Mounted on an aluminum unit
- Usable on copper, zinc, stainless steel and aluminum pipes
- Adaptable without tools on all screw guns



Easy to use directly on the worksite, flaring units for downpipes make it possible to easily and evenly electric welded (ERW) downpipes.

## GENERAL FEATURES

- Flaring depth max : 100 mm max
- Flaring rate : between 150t/ min and 500 t/ min
- Max capacity 400 N/mm<sup>2</sup> steel and stainless steel : 0.5 mm
- Max capacity zinc / ¼ hard copper : 0.8 mm
- Net weight of set with carrying case : 1.15 kg

Offer available on our website: <https://www.jouanel.com/en/page/second-hand-machines.php>



**Would you like more information about this machine?**

You can contact **+33 2 47 65 47 65 5** (from Monday to Friday 08h00 / 17h00) or send an email to: [sav@jouanel.com](mailto:sav@jouanel.com)

Ref. JOUANEL

CCM

Gross price Excl. Tax

**320 €**

Transport

Not included, possibility to quote the transport

Warranty

6 months, revised

Lead time

Available

## STANDARD EQUIPMENT

- Aluminum body, easy to handle and sturdy
- Tempered steel rollers for a better lifetime
- Guide rail and grip handle guaranteeing cutting accuracy

## MORE AVAILABLE



*The picture shown are not contractual*

Roller shear

## GENERAL FEATURES

- Capacity :

Zinc	0,8 mm
Steel	0,7 mm
Aluminum 1050-H44	0,8 mm

## COMPATIBLE MACHINES

- PBS2040 - 2540
- PCH1020
- PCL1020 - 1020A
- PCX1020
- PCX2040 - 2040A - 2540 - 3040 - 3080
- PZA2040 - 2040A
- PZX2040 - 2540

Offer available on our website: <https://www.jouanel.com/en/page/second-hand-machines.php>



**Would you like more information about this machine?**

You can contact **+33 2 47 65 47 65** (from Monday to Friday 08h00 / 17h00) or send an email to:  
[sav@jouanel.com](mailto:sav@jouanel.com)

Ref. JOUANEL

CCMA

Gross price Excl. Tax

**350 €**

Transport

Not included, possibility to quote the transport

Warranty

6 months, revised

Lead time

Available

## STANDARD EQUIPMENT

- Aluminum body, easy to handle and sturdy
- Tempered steel rollers for a better lifetime
- Guide rail and grip handle guaranteeing cutting accuracy

**MORE AVAILABLE**



*The picture shown are not contractual*

Roller shear

## GENERAL FEATURES

- Capacity :

Zinc	0.8 mm
Steel	0.63 mm
Alu	0.8 mm

## COMPATIBLE MACHINES

- All folders with a CCMA compatible rail

Offer available on our website: <https://www.jouanel.com/en/page/second-hand-machines.php>

**Would you like more information about this machine?**



You can contact **+33 2 47 65 47 65** (from Monday to Friday 08h00 / 17h00) or send an email to:  
[sav@jouanel.com](mailto:sav@jouanel.com)



Ref. JOUANEL

RCX2040A + CCM

Gross price Excl. Tax

**480€**

Transport

Not included, possibility to quote the transport

Warranty

6 months, revised

Lead time

Available

## STANDARD EQUIPMENTS

- Folding device on the front of the bending machine
- Allows the use of the CCM Wheel Knife for cutting material to the pre-bend path
- CCM cutting capacities : Zinc : 0,8 mm



Guide rail with CCM wheel knife, for PCX2040A bending machine

Offer available on our website: <https://www.jouanel.com/en/page/second-hand-machines.php>

### Would you like more information about this machine?



You can contact **+33 2 47 65 47 65** (from Monday to Friday 08h00 / 17h00) or send an email to:  
[sav@jouanel.com](mailto:sav@jouanel.com)

Ref. JOUANEL

PALCD420 (Double hinge dripe hedge benders)

Gross price Excl. Tax

313 €

Transport

Not included, possibility to quote the transport

Warranty

6 months, revised

Lead time

Available

## STANDARD EQUIPMENT

- An innovative 2-axis clamping and bending system
- A single clamp replaces the straight clamp and the angled clamp
- Only one positioning to fold down the drip edge, maximum time saving
- Easy and reproducible folding, without marking
- Suitable for standing seam trays made with 500 and 650mm coils
- Weatherproof clamp, made of stainless steel and aluminum

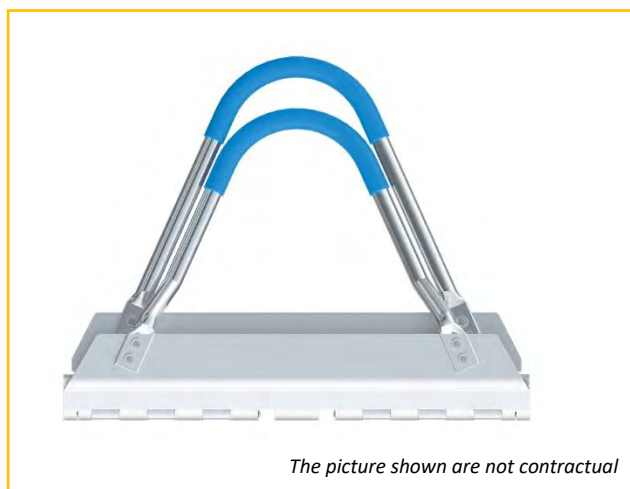

*The picture shown are not contractual*

This new innovative system of folding machines with double fold drip edges allows rapid shaping of the drip edge at the level of the sewer strip in a standing seam.

## GENERAL FEATURES

- Dimensions: L. 420mm x H.355mm
- Open length: 520 mm
- Weight: 1 790g

Offer available on our website: <https://www.jouanel.com/en/page/second-hand-machines.php>

**Would you like more information about this machine?**



You can contact +33 2 47 65 47 65 (from Monday to Friday 08h00 / 17h00) or send an email to:

[sav@jouanel.com](mailto:sav@jouanel.com)

Ref. JOUANEL	PLI01K8
Gross price Excl. Tax	200 €
Transport	Not included, possibility to quote the transport
Warranty	6 months, revised
Lead time	Available

## STANDARD EQUIPMENT

- Leaves no trace on pre-patinated and pre-lacquered sheets
- Made with non-oxidizing materials
- Handy clamp, compacts and designed especially for quality achievement
- Sturdy, the folder is perfect for starting seam for short facades or with difficult access



Extremely sturdy, light and handy, this tool is designed to close the first seam of standing seams' trays. It's ideal for heads' link fixation, short facades or difficult access.

## GENERAL FEATURES

- Weight : 2,2 kg

## CUTTING CAPACITIES

- Working width : 250 mm
- Closing seam width : 180 mm
- Maximum width of utilization :
  - Aluminum, copper, zinc : 0,8 mm
  - Steel : 0.8 mm
  - Stainless steel : 0.5 mm

Offer available on our website: <https://www.jouanel.com/en/page/second-hand-machines.php>

### Would you like more information about this machine?



You can contact +33 2 47 65 47 65 (from Monday to Friday 08h00 / 17h00) or send an email to: [sav@jouanel.com](mailto:sav@jouanel.com)

Ref. JOUANEL	PLI01NM
Gross price Excl. Tax	<b>94€</b>
Transport	Not included, possibility to quote the transport
Warranty	6 months, revised
Lead time	Available

## STANDARD EQUIPMENT

- For standing seam profile trays
- Enables a rapid and economic implementation

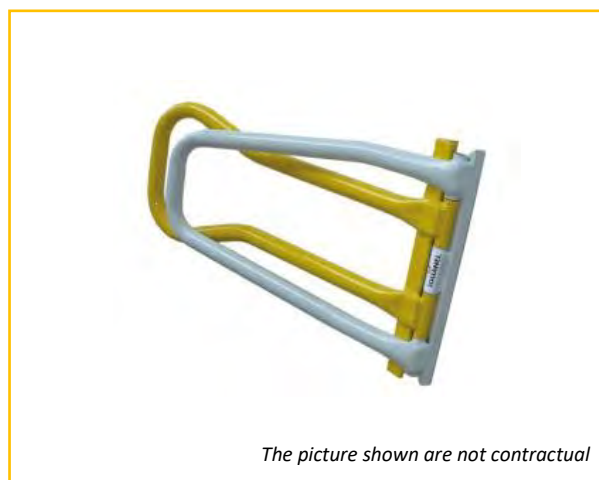

Allows to close the 1<sup>st</sup> seam of trays in standing seam, roofing or cladding

## GENERAL FEATURES

- Weight : 1 930g
- Dimensions : 390 mm x 220 mm

## FOLDING CAPACITY

- Working width : 220 mm

Offer available on our website: <https://www.jouanel.com/en/page/second-hand-machines.php>

### Would you like more information about this machine?



You can contact **+33 2 47 65 47 65** (from Monday to Friday 08h00 / 17h00) or send an email to: [sav@jouanel.com](mailto:sav@jouanel.com)

# SECOND HAND OFFER

N° OC4089

Ref. JOUANEL	PLI02NM
Gross price Excl. Tax	<b>106€</b>
Transport	Not included, possibility to quote the transport
Warranty	6 months, revised
Lead time	Available

## STANDARD EQUIPMENT

- For standing seam profile trays
- Enables a rapid and economic implementation



2<sup>nd</sup> seam folder of trays in standing seam, roofing or cladding

## GENERAL FEATURES

- Weight : 2 240g
- Dimensions : 450 mm x 220 mm

## FOLDING CAPACITY

- Working width : 220 mm

Offer available on our website: <https://www.jouanel.com/en/page/second-hand-machines.php>

### Would you like more information about this machine?



You can contact **+33 2 47 65 47 65** (from Monday to Friday 08h00 / 17h00) or send an email to: [sav@jouanel.com](mailto:sav@jouanel.com)



Ref. JOUANEL

OFF-180

Gross price Excl. Tax

**160 €**

Transport

Not included, possibility to quote the transport

Warranty

6 months, revised and repainted

Lead time

Available

## STANDARD EQUIPMENT

- Folds evenly along the whole length, starting from a 135° fold
- Closes hems at 180° in just one run
- A real time saver
- Capacity of folding 0.8 mm steel
- 4 sets of rollers
- adjustable upper roller in position and depth
- 2 grip handles



*The picture shown are not contractual*

Starting with a 135° seam, the OFF-180 tool enables you to seam at 180° in just one quick and comfortable run, thanks to its 4 sets of rollers

## GENERAL FEATURES

- 4 sets of rollers
- Adjustable upper roller in position and depth
- Steel Capacity : 0.8 mm
- 2 adjusting wheels
- Net weight : 1.8 kg

Offer available on our website: <https://www.jouanel.com/en/page/second-hand-machines.php>

**Would you like more information about this machine?**



You can contact **+33 2 47 65 47 65** (from Monday to Friday 08h00 / 17h00) or send an email to:

[sav@jouanel.com](mailto:sav@jouanel.com)

Ref. JOUANEL	PLIMSC2-100
Gross price Excl. Tax	180 €
Transport	Not included, possibility to quote the transport
Warranty	6 months, revised
Lead time	Available

## STANDARD EQUIPMENT

- For straight or curved sheets
- 2 guide rolls
- Folder roller made of hardened steel, inclined at 10°
- Graduations in mm, indelible laser engraving
- Fast locking of edge height by butterfly handle
- Handle enabling to keep a correct handling of the tool, even with a maximum edge height

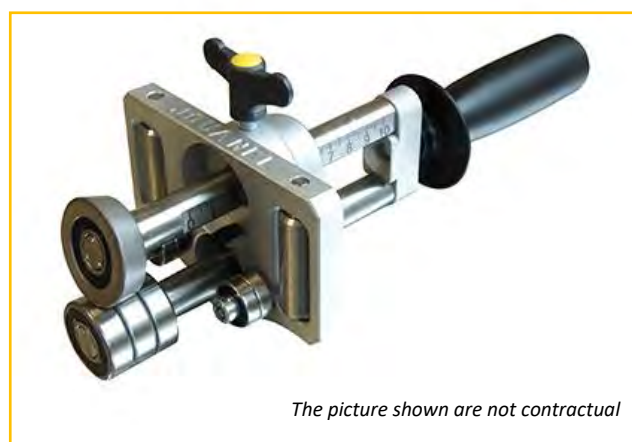

The folding roller inclined at 10°, specifically designed for bending without marking the material, will also make it possible to compensate for the spring back of the metal and thus obtain a true 90° fold.

## GENERAL FEATURES

- 2 rolls Edge height : 5 to 100 mm
- Weight : 1 165 g

## CAPACITE DE PLIAGE

- Zinc et Alu : 1.0 mm
- Cuivre / Acier : 0.8 / 0.7 mm
- Inox : 0.5 mm

Offer available on our website: <https://www.jouanel.com/en/page/second-hand-machines.php>



### Would you like more information about this machine?

You can contact +33 2 47 65 47 65 5 (from Monday to Friday 08h00 / 17h00) or send an email to: [sav@jouanel.com](mailto:sav@jouanel.com)

Ref. JOUANEL	PLIMSC2-350
Gross price Excl. Tax	350 €
Transport	Not included, possibility to quote the transport
Warranty	6 months, revised
Lead time	Available

## STANDARD EQUIPMENT

- For straight or curved sheets
- 2 guide rolls
- Folder roller made of hardened steel, inclined at 10°
- Graduations in mm, indelible laser engraving
- Fast locking of edge height by butterfly handle
- Handle enabling to keep a correct handling of the tool, even with a maximum edge height

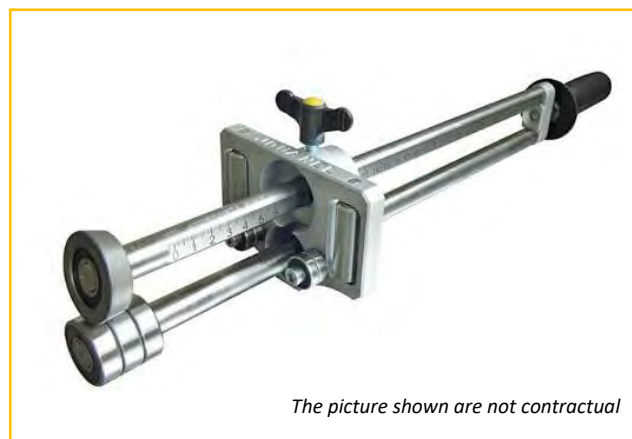

The folding roller inclined at 10°, specifically designed for bending without marking the material, will also make it possible to compensate for the spring back of the metal and thus obtain a true 90° fold.

## GENERAL FEATURES

- 2 rolls Edge height : 5 to 350 mm
- Weight : 1 925 g

## CAPACITIES

- Zinc et aluminum : 1.0 mm
- Copper / Steel : 0.8 / 0.7
- Stainless steel : 0.5 mm

Offer available on our website: <https://www.jouanel.com/en/page/second-hand-machines.php>



### Would you like more information about this machine?

You can contact **+33 2 47 65 47 65 5** (from Monday to Friday 08h00 / 17h00) or send an email to: [sav@jouanel.com](mailto:sav@jouanel.com)

Ref. JOUANEL

PLIMDC3-200

Gross price Excl. Tax

**427 €**

Transport

Not included, possibility to quote the transport

Warranty

6 months, revised

Lead time

Available

## STANDARD EQUIPMENT

- Seams on large lengths
- 3 rolls for a better guidance
- 2 folder rollers made of treated steel, inclined at 10°
- Monobloc body in anodized stainless steel
- Columns, rolls and axis made of stainless steel
- Graduations in mm, indelible laser engraving
- Fast locking edge height by 2 butterfly handles

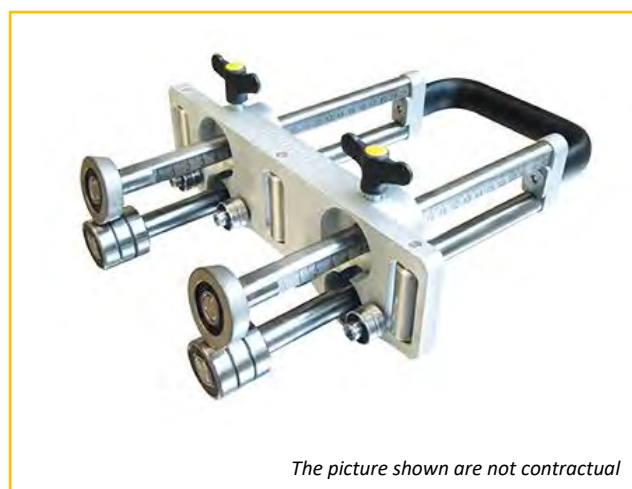

Its large coated handle allows a very good handling of the tool and its 2 folder rollers improve the stability of the sheet and the quality of folding on some edges of large dimension.

## GENERAL FEATURES

- 3 rolls edge height : 5 to 200 mm
- Weight : 3 075 g

## FOLDING CAPACITY

- Zinc and aluminum : 1.0 mm
- Copper : 0.8 mm
- Steel : 0.7 mm
- Stainless steel : 0.5 mm

Offer available on our website: <https://www.jouanel.com/en/page/second-hand-machines.php>

**Would you like more information about this machine?**



You can contact **+33 2 47 65 47 65** (from Monday to Friday 08h00 / 17h00) or send an email to:

[sav@jouanel.com](mailto:sav@jouanel.com)

Ref. JOUANEL

PLIMDC3-350

Gross price Excl. Tax

483 €

Transport

Not included, possibility to quote the transport

Warranty

6 months, revised

Lead time

Available

## STANDARD EQUIPMENT

- 3 guide rollers
- 2 Treated steel brake rollers
- One-piece body aluminum, machined and anodized
- Graduations in mm, indelible laser engraving
- Double lifting height lock by butterfly handles
- Sheathed handle
- Fabric storage pocket

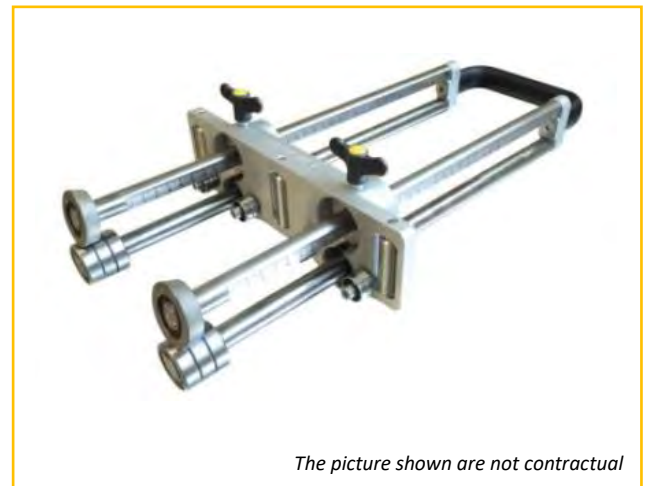

Its large coated handle allows a very good handling of the tool and its 2 folder rollers improve the stability of the sheet and the quality of folding on some edges of large dimension.

## GENERAL FEATURES

- Double column
- 3 guide rollers
- Edge height from 5 to 350 mm

## CAPACITES

Zinc / aluminum	1.0mm
Copper	0.8mm
Steel	0.7mm
Stainless steel	0.5mm

Offer available on our website: <https://www.jouanel.com/en/page/second-hand-machines.php>

### Would you like more information about this machine?



You can contact **+33 2 47 65 47 65** (from Monday to Friday 08h00 / 17h00) or send an email to:

[sav@jouanel.com](mailto:sav@jouanel.com)



Ref. JOUANEL	PLIMSD1-040
Gross price Excl. Tax	<b>182 €</b>
Transport	Not included, possibility to quote the transport
Warranty	6 months, revised and repainted
Lead time	Available

### STANDARD EQUIPMENT

- Single-piece body made of aluminum, machined and anodized
- 1 roll in stainless steel
- 1 folder roller made of 100-mm diameter hardened steel
- Removable handle
- Fabric storage pocket



Single disk hand edge roller equipped with a disk and a disengageable guide roll to make 180° hems.

### CAPACITIES

- Weight : 630 g

### OPTIONS

- High edge : 8 to 40 mm
- Bending :

Zinc / aluminum	1.0 mm
Copper	0.8 mm
Steel	0.7 mm
Stainless steel	0.5 mm

Offer available on our website: <https://www.jouanel.com/en/page/second-hand-machines.php>

### Would you like more information about this machine?



You can contact **+33 2 47 65 47 65** (from Monday to Friday 08h00 / 17h00) or send an email to: [sav@jouanel.com](mailto:sav@jouanel.com)

Ref. JOUANEL

PACK BALOUT AND TOOLING

Gross price Excl. Tax

**388 €**

Transport

Not included, possibility to quote the transport

Lead time

Available

## STANDARD EQUIPMENT

- BALOUT x1 : Luggage for tools in reinforced textile, 18 pockets
- CBID x1 : Shape and straight cutting snips, cut to the right, 280mm
- CBIG x1 : Shape and straight cutting snips, cut to the left, 280mm
- MACD x1 : **Right slater's hammer**, wooden handle, wide peen
- PATHR4K x1 : Red tracing powder of high quality, 4 kg
- PATHBL4K x1 : Black tracing powder of high quality, 4 kg
- PAR55G x1 : Cutting punching clamp for slates, blade of 55 mm
- VVDS05 x2 : stretcher for straps 10 to 20 mm wide
- CGRO x2 : Oblong nibbler shear 35 x 3 mm
- CPIDQS x1 : Shear pass sheeting pelican-shaped OS, with spring
- PBTRI100 x1 : Triangular clinching pliers, 100 mm, 100 mm depth
- PBD40 and PBC40 : Right clamp - Fold width : 40 mm - Fold depth : 45 mm



**CBID and CBIG** : Designed for small cuts of complexes forms – Counter spring removable and PVC coated handles

**MACGS** : Tool forged and polished – Wide peen for a better hand release – Sharp tip allowing to put holes in the slate to nail it – Nail-puller

**BALOUT** : Maximum weight : 15 kg – Velcro fastener – Size (mm) : 520 x 260 x 250 – Transport bar with foam

**PATHR4K** : Red powder of high quality – Made in France – Storage in jug

**PATHBL4K** : Blue powder of high quality – Made in France – Storage in jug

**PAR55G** : Cuts' width : 7 mm maximum – Punching diameter : 3,2 mm – Shearing length : 2,8 mm – Graduation of 60 mm – The blades, matrices, punching, springs and handles are interchangeable



**Would you like more information about this machine?**

You can contact **+33 2 47 65 47 65** (from Monday to Friday 08h00 / 17h00) or send an email to:  
[sav@jouanel.com](mailto:sav@jouanel.com)

**CGRO** : Adjustable cuts' width with a simple setting – Oblong's size : 35 x 3 mm – Zinc and aluminum capacity : 0,8 mm / steal : 0,6 mm

**CPIDQS** : Blades and branches forged – Long and strong blades to ease the continuous strikes – Stopper anti-pinching fingers – Counter spring removable – Capacities : steel : 0,6 mm; copper / aluminum : 1,2 mm, stainless steel : 0,4 mm

**PBTRI100** : Versatile clamp – Crossed-hinge for more strength – Fold width : 100 mm – Handle PVC-coated for a comfortable utilization.

**PBD40 / PBC40** : Right clamp and bent pliers bent to 45° - Fold width : 40 mm - Fold depth : 45 mm Crossed-hinge - PVC-coated handle for a comfortable utilization

Offer available on our website: <https://www.jouanel.com/en/page/second-hand-machines.php>



**Would you like more information about this machine?**

You can contact **+33 2 47 65 47 65 5** (from Monday to Friday 08h00 / 17h00) or send an email to:

[sav@jouanel.com](mailto:sav@jouanel.com)